



## A NEW IMPROVED OF INCORPORATING PHOTOVOLTAIC ENERGY INTO THE PRODUCTION OF GREEN HYDROGEN

Yacine BENCHENINA <sup>1,2,\*</sup> , Abderrahim ZEMMIT <sup>1</sup> , Mohammed Moustafa BOUZAKI <sup>3</sup> , KHALED BELHOUCHE <sup>1</sup> 

<sup>1</sup> Electrical Engineering Department, University of Msila, Algeria

<sup>2</sup> LGE Research Laboratory of M'sila, Algeria

<sup>3</sup> Renewable Energy Department, University of Blida 1, Algeria

\* Corresponding author, e-mail: [yacine.benchenina@univ-msila.dz](mailto:yacine.benchenina@univ-msila.dz)

### Abstract

The integration of renewable energies, particularly photovoltaic energy, into green hydrogen production presents a highly promising prospect in the energy sector. Nonetheless, these energy sources face challenges due to their inherent instability and susceptibility to various atmospheric factors such as temperature and illumination. Therefore, it's imperative to tackle these challenges before renewable energy can be widely adopted as a primary source in hydrogen production. To address this, we propose constructing an autonomous photovoltaic system using MATLAB software. This system will employ a DC-DC boost converter to connect the PV array to the load. Furthermore, to enhance the efficiency of photovoltaic power generation, we will implement the perturbation and observation maximum power point tracking (MPPT) approach. The research endeavor extends towards integrating this optimized system with an electrolyser developed a sophisticated electrolyte model utilizing MATLAB Simulink software, paving the way for hydrogen gas production.

Keywords: perturbation and observation, green hydrogen, MPPT, boost converter, photovoltaic system

## 1. INTRODUCTION

Utilizing renewable energies, especially photovoltaic solar power for hydrogen production, presents a viable solution to escalating electricity demands due to its cleanliness and natural abundance. However, its inherent volatility, influenced by climatic variables like light intensity and temperature, necessitates precise control mechanisms such as the Maximum Power Point (MPP) [1]. This study employs the Perturbation and Observation method to track the MPP, offering advantages of simplicity, independence from PV array specifics, accuracy, and high performance under uniform radiation.

The paper's structure unfolds in the following manner: Section 2 provides a concise system overview, followed by Section 3 which concentrates on system modeling. Section 4 explores the implementation of Perturb and Observe (P&O) control for monitoring photovoltaic system output. Section 5 elaborates on the modeling of an advanced electrolyzer using Matlab and the integration of this component with the photovoltaic energy source, along with the exploration of novel technologies for controlling energy conversion to establish an

integrated and highly optimized system for green hydrogen production. Simulation outcomes are detailed in Section 6, with Section 7 summarizing the key findings and conclusions derived from this study.

## 2. OUTLINE OF THE PROPOSED SYSTEM'S FEATURES

Illustrated in Figure 1, the modeling process of the photovoltaic system intricately involves three primary components, each wielding significant influence over the system's functionality and performance. The photovoltaic (PV) array, acting as the cornerstone of solar energy capture, consists of interconnected solar cells engineered to efficiently convert incident sunlight into electrical energy [2]. Complementing the PV array, the boost converter assumes a pivotal role in voltage regulation, amplifying the generated direct current (DC) to levels conducive for effective power transmission and utilization. Meanwhile, the controller system, equipped with sophisticated algorithms and feedback mechanisms, orchestrates the intricate interplay between the PV array and the boost converter, dynamically adjusting operational

parameters to optimize energy conversion efficiency and adapt to varying environmental conditions [3]. This holistic approach to modeling not only affords a comprehensive understanding of the individual components' characteristics but also enables a nuanced analysis of their collective behaviour, facilitating informed decision-making and the refinement of photovoltaic system designs for enhanced performance and sustainability [4].

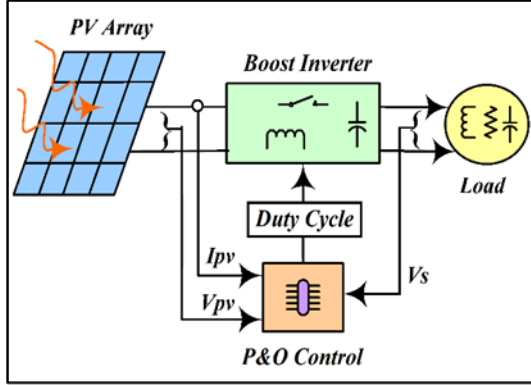

Fig. 1. The Proposed System

Photovoltaic (PV) electrolyzers harness solar energy, typically from photovoltaic panels, to conduct electrolysis, splitting water molecules into hydrogen and oxygen gases. These gases serve as clean energy carriers for various applications. Existing systems include Proton Exchange Membrane (PEM), Alkaline, Solid Oxide (SOE), and Flow Electrolyzers [5]. They vary in operation temperature, efficiency, and scalability. Integrated systems incorporate energy storage for continuous hydrogen production, while hybrid systems combine multiple renewable sources for improved efficiency. PV electrolyzers are vital for a sustainable energy future, evolving through ongoing research to enhance efficiency, cut costs, and broaden applications [7].

Fundamentally, the electrolyzer's design comprises two half-cells separated by a thin, proton-conducting, insulating Proton Exchange Membrane (PEM) positioned at the center of the cell. Adjacent to each side of the membrane lies a layer of porous catalyst where the electrochemical reactions occur. The combination of PEM and catalyst layers constitutes the Membrane Electrode Assembly (MEA). Enclosing the MEA is a current collector, establishing physical and electrical connections between the catalyst layer and the bipolar plate. The bipolar plate, in turn, serves as a structural element that ensures the cell's integrity, facilitates the movement of reactants and products, and isolates individual cells within a stack configuration [8].

The electrolyzer undergoes several reactions, including anodic, cathodic, and overall processes, which are outlined below:

**Anodic reaction:**

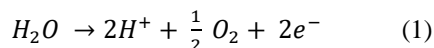

**Cathodic reaction:**

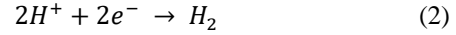

**Global reaction:**

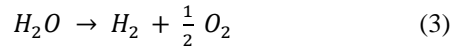

### 3. DEVELOPING A MODEL FOR THE PROPOSED SYSTEM

#### 3.1. Creating a Model for Photovoltaic Panel

An ideal solar cell is often represented by a current source connected in parallel to a diode. However, real-world solar cells exhibit imperfections, prompting the model to incorporate additional components. In the illustrated Figure 2, two resistances are introduced—one in series and another in parallel—to account for these imperfections [6].

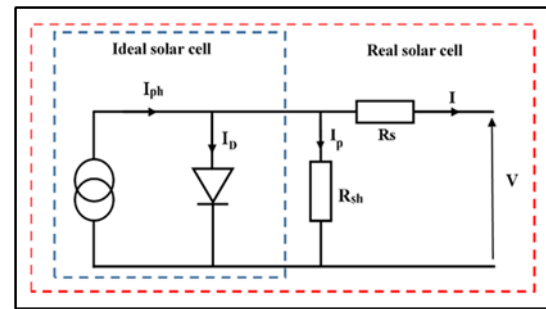

Fig. 2. Electrical Modeling of Solar Cells

When light illuminates the surface of a solar cell, it activates its unique capability to convert light energy into electrical current. In essence, the solar cell behaves similarly to a diode under illumination, exhibiting comparable electrical characteristics. Consequently, the electrical behaviour of a solar cell featuring a PN junction can be mathematically described using the following equations [6]:

**Photocurrent ( $I_{ph}$ ):**

$$I_{ph} = [I_{sc} + K_i \cdot (T - 298)] \cdot \frac{G}{1000} \quad (1)$$

**Saturation current ( $I_0$ ):**

$$I_0 = I_{rs} \cdot \left(\frac{T}{T_n}\right)^3 \cdot (T - 298) \cdot \exp\left[\frac{q \cdot E_{g0} \cdot \left(\frac{1}{T_n} - \frac{1}{T}\right)}{n \cdot k}\right] \quad (2)$$

**Saturation Current in Reverse Bias ( $I_{rs}$ ):**

$$I_{rs} = \frac{I_{sc}}{e^{\left(\frac{q \cdot V_{oc}}{n \cdot N_s \cdot K \cdot T}\right) - 1}} \quad (3)$$

**Current Flow Across Shunt Resistor ( $I_{sh}$ ):**

$$I_{sh} = \left(\frac{V + I \cdot R_s}{R_{sh}}\right) \quad (4)$$

**Output current ( $I$ ):**

$$I = I_{ph} - I_0 \cdot \left[\exp\left(\frac{q \cdot (V + I \cdot R_s)}{n \cdot K \cdot N_s \cdot T}\right) - 1\right] - I_{sh} \quad (5)$$

Where  $I_{sc}$ : Short-circuit current,  $K_i$ : the Temperature coefficient,  $T$ : the Temperature,  $G$  is the Incident irradiance,  $T_n$ : the Nominal temperature,  $q$ : Elementary charge,  $E_{g0}$ : Bandgap

energy at reference temperature,  $k$  : Boltzmann constant,  $V_{oc}$  : Open-circuit voltage,  $N_s$  : Number of series cells,  $R_s$  : Series resistance,  $R_{sh}$  : Shunt resistance.

### 3.2. MPPT Control Strategy: Perturb and Observe Algorithm

The Perturbation and Observation (P&O) algorithm is widely acknowledged as a prominent method in literature and practical applications due to its straightforward implementation. This algorithm utilizes PV module input voltage ( $V_{pv}$ ) and PV module current ( $I_{pv}$ ) values to calculate the duty cycle. It begins by perturbing the voltage ( $V_{pv}$ ) through adjusting the duty cycle, then evaluates and compares the power output of the solar panel with its previous state. As the power output increases, the algorithm approaches the Maximum Power Point (MPP), leading to consistent adjustments in the duty cycle. Conversely, a decrease in power output indicates deviation from the MPP, prompting a reversal in the direction of duty cycle adjustments. The accompanying figure illustrates how the power and voltage characteristics of a solar generator respond to changing weather conditions [10] .

Next, we will delve into the details of the Perturbation and Observation control algorithm.

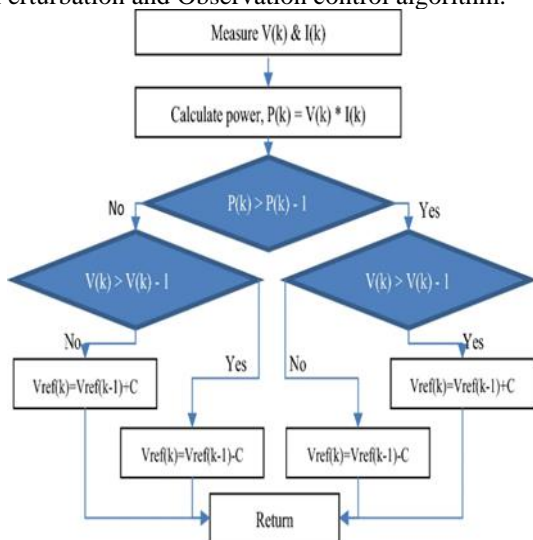

Fig. 3. Perturbation and observation control algorithm

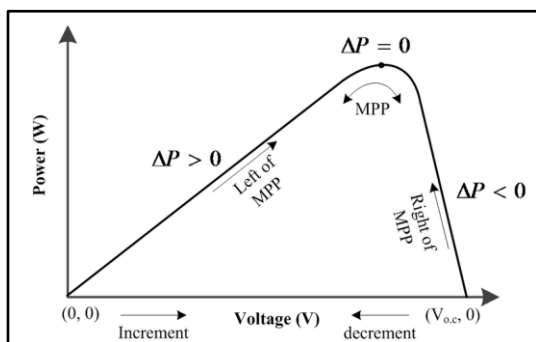

Fig. 4. Typical Power-Voltage characteristic

### 3.3. Modeling of the Electrolyzer

For the second part of this investigation, we developed a sophisticated electrolyte model utilizing MATLAB Simulink software. The system architecture comprises two distinct components: the anode section, featuring fluid channels linked to a heat exchanger and a recirculation system to enhance operational efficiency, with water sourced from a dedicated water tank. Conversely, the cathode section consists of fluid channels connected to a dehumidifier to isolate water vapour from the generated hydrogen, which is subsequently stored in a hydrogen tank. Additionally, a cooling mechanism is employed to maintain optimal system temperature, as depicted in Figure 11. Three distinct energy profiles were employed as power sources: Solar power profile, Step current, and Ramp current, as illustrated in Figure 5 [14].

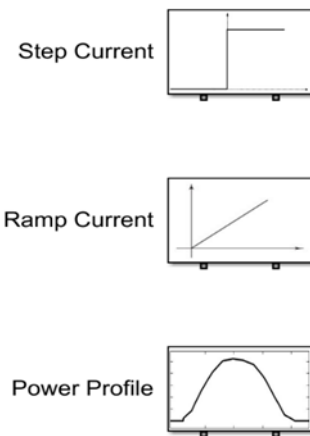

Fig. 5. Typical Power-Voltage characteristic

## 4. SIMULATION RESULTS

### 4.1. Energy source

In this simulation, we consider an irradiation value of 1000 W/m<sup>2</sup> and maintain a constant temperature of 25°C. These parameters are chosen to meticulously evaluate the efficacy of the Perturbation and Observation (P&O) strategy employed in the DC/DC converter [11].

Table 1. PV Model

PV Model: SPR-225-BLK-U	
Maximum power	$P_{mpp} = 213.15 \text{ W}$
Voltage of maximal power	$V_{mpp} = 29 \text{ V}$
Current of maximal power	$I_{mpp} = 7.35 \text{ A}$
Open-circuit Voltage	$V_{oc} = 36.3 \text{ V}$
Short-circuit current	$I_{sc} = 7.84 \text{ A}$
Cell numbers	60
Temperature coefficient of the maximum power	- 0.360%
Reference temperature	$T_r = 25\text{°C}$
Boltzmann Constant	$K = 1.3805 \cdot 10^{-23} \text{ J/K}$
Electron charge	$q = 1.6 \cdot 10^{-19} \text{ C}$

The simulation outcomes unveil the remarkable adaptability and stability of the photovoltaic (PV)

system across diverse irradiation conditions. Notably, the PV system adeptly sustains its peak power output throughout the simulation, showcasing its capacity to efficiently harness solar energy despite fluctuations in irradiation levels [12].

Furthermore, the system exhibits exceptional performance in external voltage regulation, steadfastly maintaining a consistent voltage level at the designated reference value of 48 V. Even amidst varying irradiation, the system promptly readjusts to this reference value, underscoring its robust voltage regulation capabilities and resilience against environmental changes. Similarly, the battery current remains impressively stable, hovering closely around the prescribed reference value.

With minimal oscillations observed. This consistent current flow reflects the efficacy of the battery management system, ensuring optimal charging and discharging processes to maximize energy storage efficiency and prolong battery lifespan.

In essence, the comprehensive analysis of the simulation data provides valuable insights into the PV system's reliability and performance under dynamic environmental conditions. Its ability to maintain peak power output, regulate external voltage, and stabilize battery current highlights its suitability for various renewable energy applications, bolstering confidence in its real-world deployment for sustainable energy generation and storage [13].

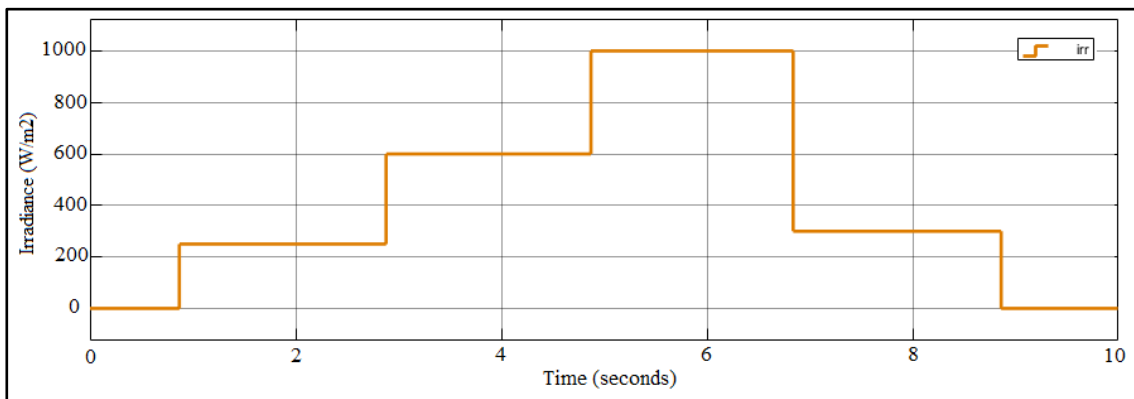

Fig. 6. Temporal Variation of Irradiance

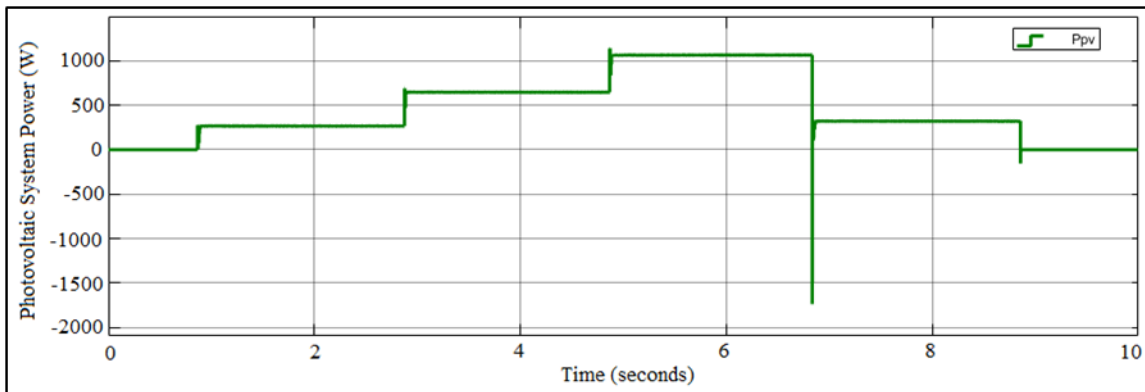

Fig. 7. Photovoltaic System Power Output

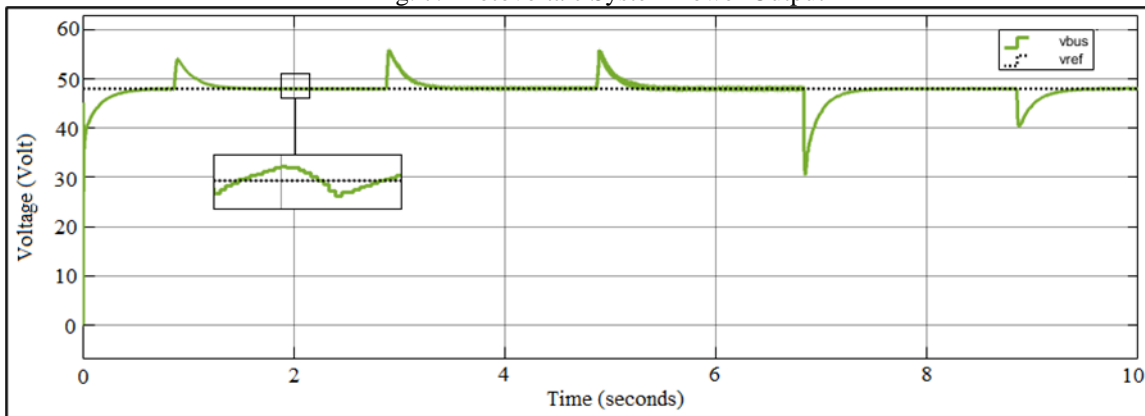

Fig. 8. Photovoltaic System Voltage Output

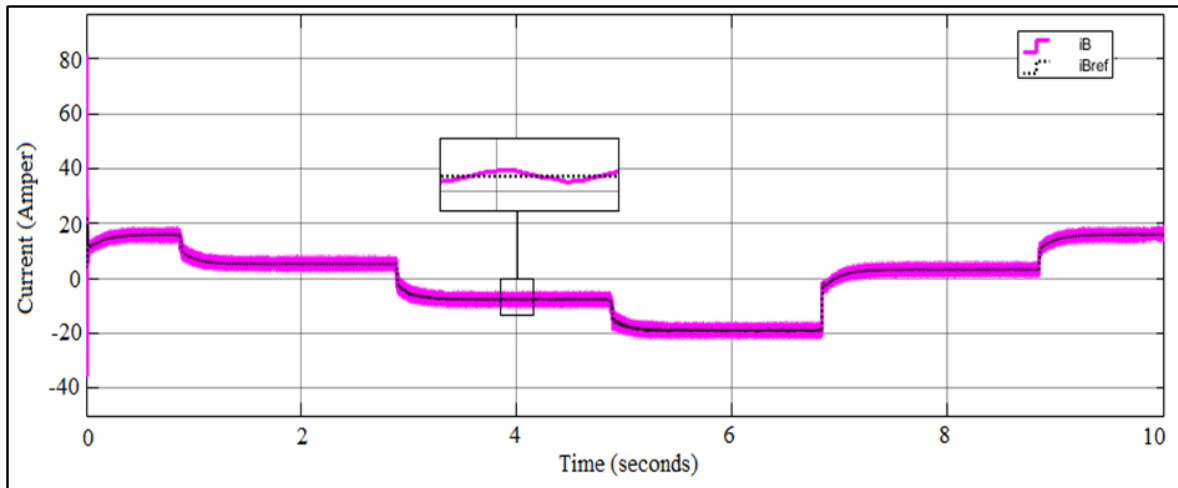

Fig. 9. Battery charging current

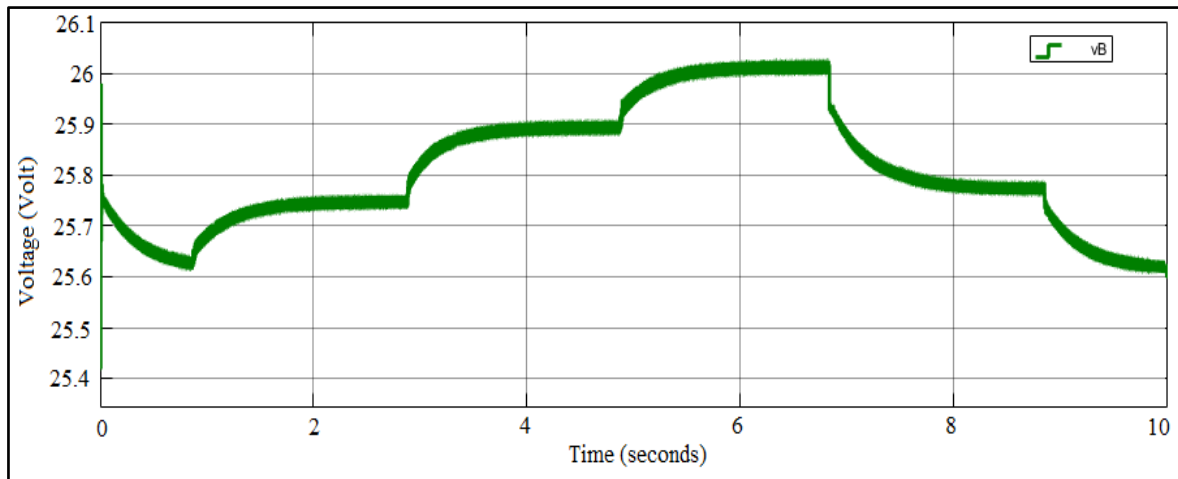

Fig. 10. Battery voltage

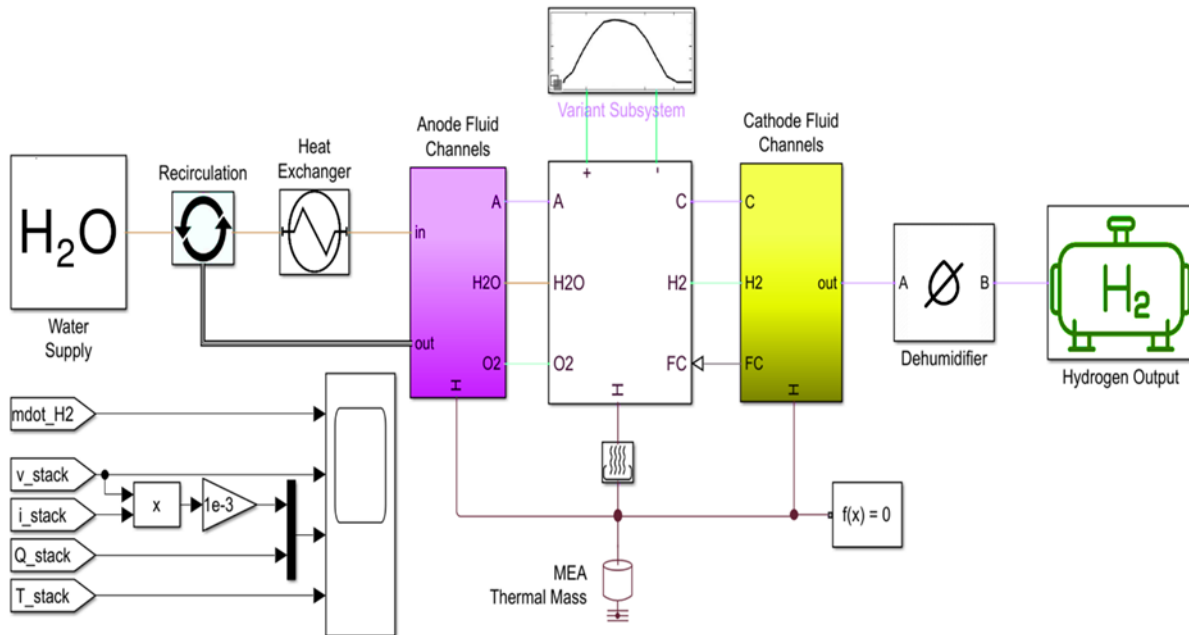

Fig. 11. Advanced Electrolyzer Simulation

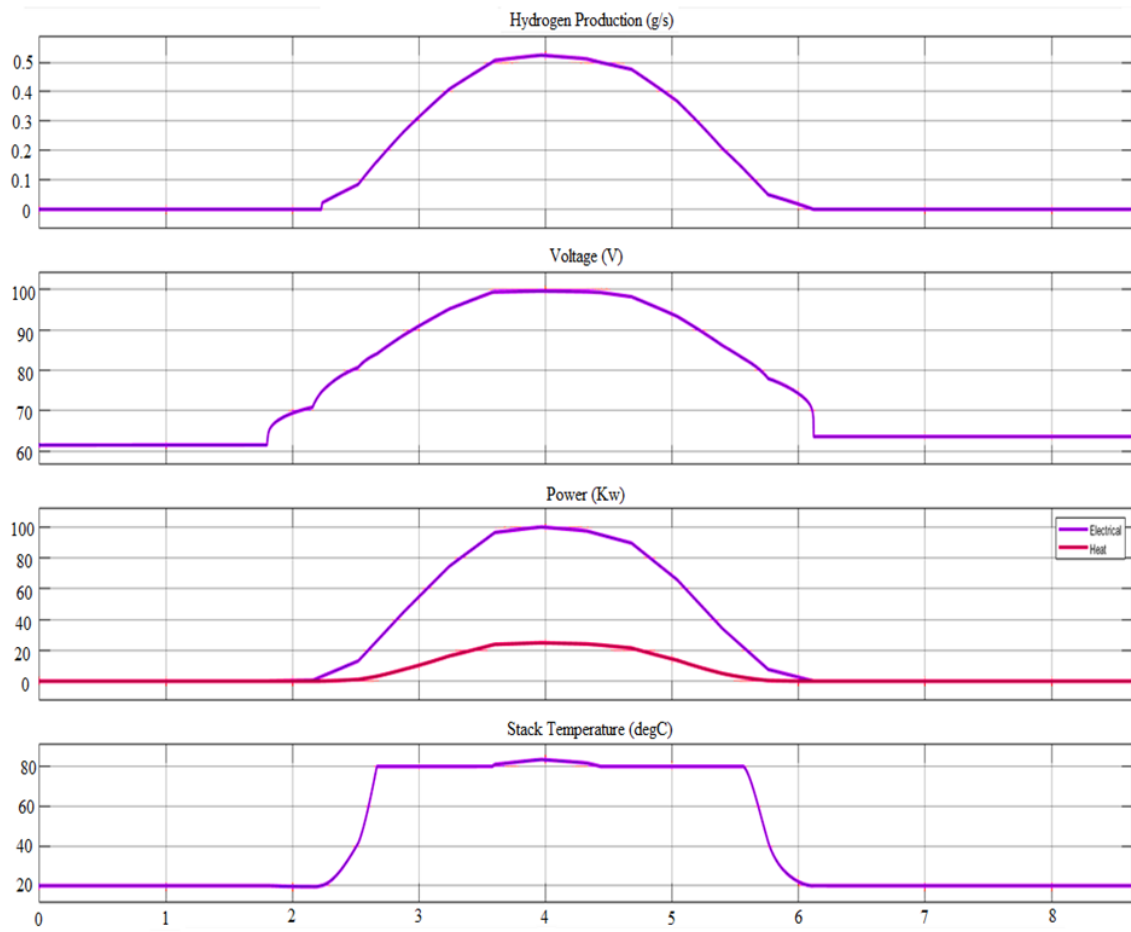

Fig. 12. Solar Power Profile graphs

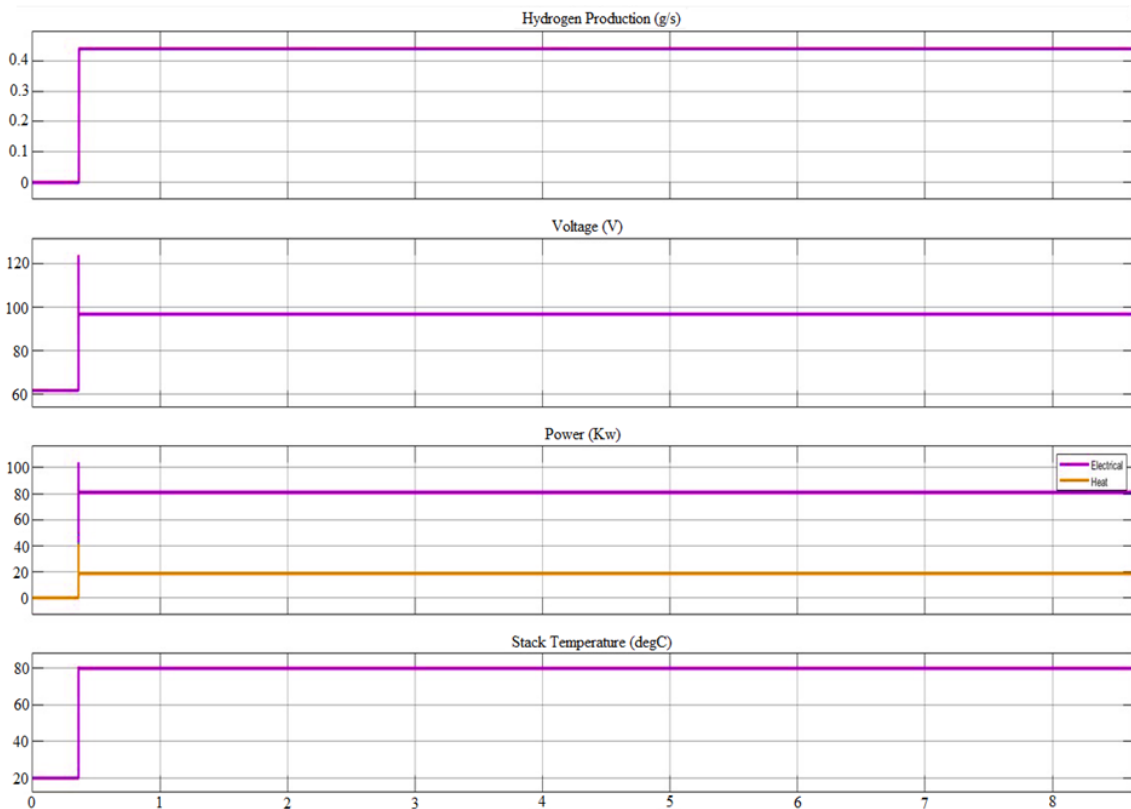

Fig. 13. Step Profile graphs

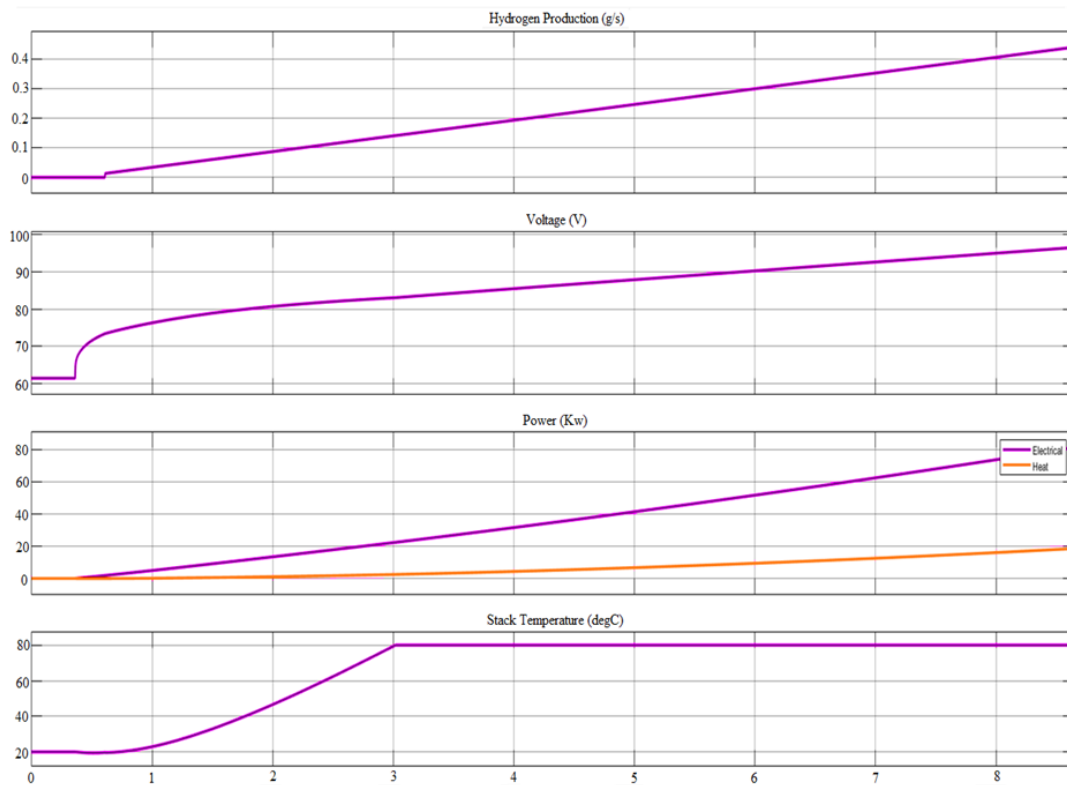

Fig. 14. Ramp Profile graphs

#### 4.1. Electrolyzer

The ensuing curves below illustrate distinct outcomes based on different configurations. In the context of the solar setup (referenced in Fig. 12), hydrogen production demonstrated an increasing trend alongside rising light intensity, peaking at 0.52 g/s before tapering off with diminishing light intensity. Correspondingly, energy output followed a similar trajectory, ascending to 100 KW with heightened light intensity before descending. As energy output surpassed requirements, surplus energy was converted to heat, reaching a maximum of 22 KW. Despite the rise in hydrogen production, the electrolyzer's temperature climbed to 80 °C but stabilized through the cooling system, ensuring operational efficiency without compromising output.

In contrast, the Step Profile (depicted in Fig. 13) exhibited a transient surge in production rate from 0 to 0.43 g/s, followed by stabilization in response to the power supply [14].

Similarly, energy spiked from 0 to 80 KW before stabilizing, with consistent heat liberation at 20 KW. Effective cooling mechanisms maintained the electrolyzer temperature at 80 °C throughout.

In the scenario of the Ramp Profile (illustrated in Fig. 14), hydrogen production steadily increased, reaching 0.45 g/s and continuing its upward trajectory. Concurrently, power output reached 80 KW, while temperature stabilized at 80 °C with cooling system support [15].

Analysis of the results indicates that despite energy losses, power output exceeded the requirement for

hydrogen production, leading to the dissipation of excess heat. The thermal efficiency of the electrolyzer, representing the proportion of electrical energy utilized for hydrogen production relative to the calorific value of hydrogen, was approximately 87%. Crucially, the cooling system effectively regulated the system temperature, preventing it from surpassing 80 °C [15].

#### 5. CONCLUSION

This paper presents a comprehensive investigation into the optimization analysis of an autonomous PV solar system. The study proposes a novel approach grounded in perturbation and observation methodology, aimed at maximizing PV power extraction. Through simulated experiments conducted using Simulink Matlab software, the efficacy of this strategy is rigorously evaluated within a boost converter-based setup.

The simulation results unequivocally validate the proposed strategy's effectiveness in tracking the Maximum Power Point (MPP) and maximizing power harvesting, irrespective of varying solar environmental conditions. This robust performance underscores the potential of the perturbation and observation technique as a reliable and adaptable solution for optimizing PV system performance.

Then, Employing Matlab Simscape, we crafted a sophisticated electrolyzer system distinguished by its advanced design. Notably, the system's productivity consistently achieved an impressive

87% yield, marking a significant milestone in our endeavors. This outcome underscores the robustness and effectiveness of our design methodology, instilling confidence in the potential for future breakthroughs in electrolysis technology.

One of the challenges confronting us pertains to the design of a practical and appropriate cooling system that guarantees the stability of the studied system. This aspect will be the primary focus of forthcoming investigations.

The forthcoming challenge involves identifying and implementing an optimal control technique tailored to efficiently manage the electrolyzer within the integrated PV system framework. Furthermore, conducting a comparative analysis between the obtained results and those derived from an authentic model to ascertain the validity of these findings. This multifaceted exploration promises to unlock new avenues for sustainable energy generation and storage, driving advancements towards a greener and more resilient energy infrastructure.

**Source of funding:** *This research received no external funding.*

**Author contributions:** *research concept and design, A.Z., Y.B., M.M.B., K.B.; Collection and/or assembly of data, A.Z., Y.B.; Data analysis and interpretation, A.Z., Y.B.; Writing the article, A.Z., Y.B., K.B.; Critical revision of the article, Y.B., A.Z.; Final approval of the article Y.B., A.Z., M.M.B.*

**Declaration of competing interest:** *The authors declare, that they have no known competing financial interests or personal relationships that could have appeared to influence the work reported in this paper.*

## REFERENCES

- Büyük M, İnci M. Improved drift-free P&O MPPT method to enhance energy harvesting capability for dynamic operating conditions of fuel cells. *Energy* 2023; 267: 126543. <https://doi.org/10.1016/j.energy.2022.126543>.
- Bayoumi MA, El Tantawy ESF, Abdallah MG, Atallah AM, Hafez DM. Investigation of green hydrogen production and storage from PV arrays connected to an AC microgrid system. 2023 International Telecommunications Conference (ITC-Egypt) 2023; 157–64. <https://doi.org/10.1109/ITC-Egypt58155.2023.10206259Ayse>
- Bilhan AK. Integrated solar-based PEMWEs for green electricity production. <https://doi.org/10.1016/j.ijhydene.2024.02.137>.
- Salem Elbarbary ZM, Awad M. Optimal design of photovoltaic/wind turbine systems for producing hydrogen using a PEM Electrolyzer and MPPT Controller. *Plos One* 2022. <https://doi.org/10.1371/journal.pone.0287772>.
- Zou L, Shen Q, Yang G, Li S, Huang N. Improved hydrogen production efficiency of a Photovoltaic-Electrolysis system with P&O Algorithm: A case study. *Chemical Physics Letters* 2023; 832: 140891. <https://doi.org/10.1016/j.cplett.2023.140891>.
- Abderrahim Zemmit. A New improved variable step size MPPT method for photovoltaic systems using grey wolf and whale optimization technique based PID controller. *Journal Européen des Systèmes Automatisés*, 2021;54(1):175-185. <https://doi.org/10.18280/jesa.540120>.
- Azad M, Sadhu P, Das S. Comparative study between p&o and incremental conduction MPPT techniques-A review. 2020 International Conference on Intelligent Engineering and Management (ICIEM), 2020:217-222. <https://doi.org/10.1109/ICIEM48762.2020.9160316>.
- Figueiredo S, Aquino RNAL. Hybrid MPPT technique PSO-P&O applied to photovoltaic systems under uniform and partial shading conditions. *IEEE Latin America Transactions* 2021; 19(10): 1610–7. <https://doi.org/10.36306/konjes.1359177>.
- Yuwanda R, Prasetyono E, Eviningsih R. Constant power generation using modified MPPT P&O to overcome overvoltage on solar power plants. 020 International Seminar on Intelligent Technology and Its Applications (ISITIA), 2020:392-39. <https://doi.org/10.1109/ISITIA49792.2020.9163685>.
- Hussein M, Mohamed M, Ahmed N, Zahran M. Comparison between P&O and SSO techniques based MPPT algorithm for photovoltaic systems. *International Journal of Electrical and Computer Engineering (IJECE)* 2022; 12: 32. <https://doi.org/10.11591/ijece.v12i1.pp32-40>.
- Alhussain H, Yasin N. Modeling and simulation of solar PV module for comparison of two MPPT algorithms (P&O & INC) in MATLAB/Simulink. *Indonesian Journal of Electrical Engineering and Computer Science* 2020; 18: 666. <https://doi.org/10.11591/ijeecs.v18.i2.pp666-677>.
- Szemes PT, Melhem M. Analyzing and modeling PV with “P&O” MPPT Algorithm by MATLAB/SIMULINK. 2020 3rd International Symposium on Small-scale Intelligent Manufacturing Systems (SIMS) 2020; 1–6. <https://doi.org/10.1109/SIMS49386.2020.9121579>.
- Abo-Khalil A, El-Sharkawy I, Radwan A, Memon S. Influence of a hybrid MPPT technique, SA-P&O, on PV system performance under partial shading conditions. *Energies* 2023; 16: 577. <https://doi.org/10.3390/en16020577>.
- Gutiérrez-Martín F, Amodio L, Pagano M. Hydrogen production by water electrolysis and off-grid solar PV. *International Journal of Hydrogen Energy* 2021; 46(57): 29038–48. <https://doi.org/10.1016/j.ijhydene.2020.09.098>.
- Patel H, Asghari Gorji S, Shahi S, Love J. Implementation of a lab-scale green hydrogen production system with solar PV emulator and energy storage system. 11th International Conference on Power and Energy Systems (ICPES), Shanghai, China, 2021:201-208. <https://doi.org/10.1109/ICPES53652.2021.9683797>.



### Yacine BENCHENINA

Graduated with a degree in renewable energy in 2019 from the University of Blida 1 in Algeria, and two years later, he earned a master degree in renewable energy photovoltaic conversion from the University of Blida 1 in Algeria. He is currently a doctoral student at the University of M'sila, the



subject of the research is improving the performance of energy systems from renewable sources based on green hydrogen.

Contact: [yacine.benchenina@univ-msila.dz](mailto:yacine.benchenina@univ-msila.dz)



**Abderrahim ZEMMIT**

born in M'cif, M'sila (Algeria) in 1990, he obtained Licenc, Master and Doctorate degrees in 2011, 2013 and 2017 respectively. His research areas are focused on the control of electro-energy systems and intelligent control. Currently, he is interested in bioinformatics and nature - inspired optimization algorithms and its

applications to renewable energy systems. He is also a member of several research projects at University of M'sila as well as a research laboratory member of mechatronics at University of Sétif1.

Contact: [abderrahim.zemmit@univ-msila.dz](mailto:abderrahim.zemmit@univ-msila.dz)



**Mohammed Moustafa BOUZAKI**

State engineer in Physics: Materials and Characterizations in 2010 from the University of Tlemcen in Algeria, then a Master 2 in material sciences option: Energy and Materials from the University of Tlemcen in Algeria in 2011. In 2017, the University of Tlemcen will award the Ph.D. in Physics -

Option: Renewable energies.

Contact: [bouzaki.moustafa@yahoo.com](mailto:bouzaki.moustafa@yahoo.com)



**Khaled BELHOUCHE**

joined M'sila university in 2015 as an Assistant Professor. He obtained then a Ph.D degree In electrical engineering from the university of Ferhat Abbas University, Setif - 1, Algeria in 2020. Currently, he is an associate Professor at Mohamed Boudiaf University in M'sila, Algeria. His

research interests are: high voltage engineering, insulation technologies, optimization methods and overvoltage protection, optimization algorithms and its applications to renewable energy systems. He is a research member at Laboratory of Electrical Engineering , University of Mohamed Boudiaf, M'sila, Algeria.

Contact: [khaled.belhouchet@univ-msila.dz](mailto:khaled.belhouchet@univ-msila.dz)